

TBL5008-2B 50 μ H LISN

The TBL5008-2B is a Line Impedance Stabilization Network designed to measure conducted emissions on power supply lines in the 9kHz to 30MHz frequency range, as specified by the CISPR 16-1-2 standard. The device is designed for testing single phase, AC-powered equipment with supply voltages up to maximum 250V and 8 A. Conducted noise can be measured on the phase and on the neutral conductor. The TBL5008-2B features separate measurement outputs for each channel to enable connectivity for a common mode / differential mode separator (LISN Mate), a PE switch to mimic an extension cable and an artificial hand connection. The device is available with country-specific EUT connectors.



TBL5008-2B, variant with Schuko connector (CEE 7/3) socket

Features

- Frequency range: 9 kHz to 30 MHz
- Impedance: 50 Ω || (50 μ H + 5 Ω)
- Artificial hand: 220 pF + 511 Ω
- Switchable PE: 50 Ω || 50 μ H
- Independent BNC outputs for line and neutral to provide connectivity for CM/DM separators (LISN Mate)
- Air core inductors
- Line voltage: max. 250V / 50/60 Hz or DC
- Max. current: 8 A @ 23°C
- EUT socket: country specific
- Measurement connector: 50 Ω BNC
- Power connector: IEC 60320 C13
- Operating Temperature Range: +5°C ... + 40°C; 5% to 80% RH

Application

- EMC conducted emission measurements

TBL5008-2B 50 μ H LISN

Contents

1	INTRODUCTION	4
1.1	PRE-COMPLIANCE TESTING OF CONDUCTED EMISSIONS	4
1.2	LINE IMPEDANCE STABILIZATION NETWORKS	4
1.3	RF OUTPUT	5
1.4	INFORMATIVE SCHEMATIC	5
1.5	PE SWITCH	6
1.6	ARTIFICIAL HAND	6
1.7	COMMON MODE / DIFFERENTIAL MODE SEPARATOR (LISN MATE) CONNECTIVITY	6
2	LABORATORY SET UP	7
2.1	GROUND PLANE	8
2.2	PRE-COMPLIANCE SETUP WITH ROLL-UP GROUND PLANE	8
3	OPERATION CHECKLIST	9
4	TBL5008-2B SPECIFICATIONS	10
4.1	CONFORMITY	10
4.2	SAFETY	10
4.3	SPECIFICATIONS	10
4.4	SUPPLY VOLTAGE	10
4.5	FRONT PANEL	11
4.6	REAR PANEL	12
4.7	IMPEDANCE	13
4.8	PHASE	13
4.9	CALIBRATION DATA ACCORDING TO CISPR 16 -1-2 ANNEX A8	14
4.10	ISOLATION	15
4.11	THERMAL CHARACTERISTICS	16
5	ORDERING INFORMATION	16
6	HISTORY	17

Tables

Table 1, TBL5008-2B LISN voltage division ratio, calibration data	15
Table 2– LISN Ordering Information	16
Table 3– History	17

TBL5008-2B 50 μ H LISN

SAFETY

Operating an AC LISN involves dealing with potentially lethal voltages and high ground leakage currents. The LISN shall only be operated by qualified staff.



Read this manual carefully and be sure to understand the operation of an AC LISN. Make sure that the conducted noise pre – compliance test equipment is set up correctly and that the necessary earth connections are reliably bonded to avoid the risk of lethal electric shocks. The ground brackets must be securely connected to the protective earth conductor available on site, before making any other electrical connection. This connection must not be separated, until the mains supply is disconnected from the LISN setup.

Always supply the LISN only through an isolation transformer.

Take precautions, such as validating the signal amplitude at the RF output prior to connecting a spectrum analyzer or using attenuators and/or limiters to prevent damage to your test receiver or spectrum analyzer.

Do not carry out any modifications or manipulations of the TBL5008-2B.

Avoid touching the housing, when operating the LISN at maximum current over extended time. The housing temperature may rise up to 50°C. Turn off the EUT after measurements to avoid unnecessary dissipation.

TBL5008-2B 50 μ H LISN

1 Introduction

1.1 Pre-compliance testing of conducted emissions

Full compliance measurement of AC mains supplied products requires a high end set up consisting of a screened chamber, a measurement receiver that complies with the requirements of CISPR 16, a 50 μ H LISN and a suitable table for the measurement setup. Great effort and cost ensure optimum accuracy and repeatability.

Pre-compliance measurements aim to characterize the Equipment Under Test's EMC performance for a fraction of the expense of full compliance testing. The availability of low-cost spectrum analyzers with EMI IF filters and Quasi-Peak detectors makes EMC pre-compliance testing feasible to any company that develops electronic products. Together with affordable test equipment from Tekbox, EMC pre-compliance set-ups cost hardly more than a standard oscilloscope a few years ago.

Eliminate uncertainty before going to the test house for compliance testing. There is hardly anything that can give you a return on invest as quickly as EMC pre compliance test equipment.

1.2 Line Impedance Stabilization Networks

Principle of conducted emission measurements:

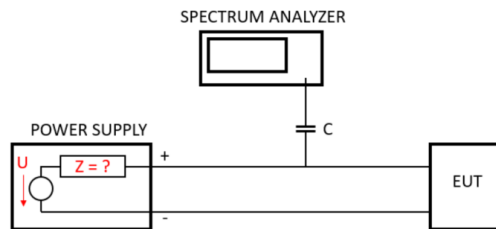

Emissions are measured by capacitively coupling to supply lines. The EUT's supply port impedance and the power supply's source impedance interact as a voltage divider for RF emissions on the supply line. Power supply source impedances are rarely specified; therefore, the results of emission measurements vary amongst power supplies.

What is the purpose of LISNs?

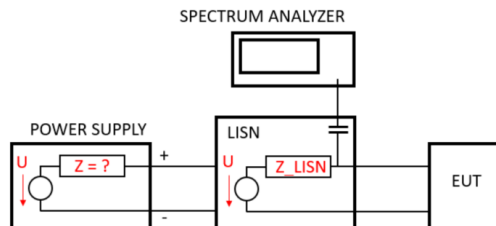

- The LISN acts as a coupler for RF on supply lines
- The LISN establishes a defined source impedance, enabling repeatable measurements
- The LISN attenuates noise coming from the supply towards the receiver/analyzer and EUT

TBL5008-2B 50 μ H LISN

1.3 RF output

The TBL5008-2B provides independent RF outputs for the phase (line) and neutral paths. This allows you to attach a common mode / differential mode separator (LISN Mate) if necessary.

Independent RF outputs are AC-coupled to the phase or neutral line. When measuring conducted emissions at the line (phase)-output, terminate the neutral-output and vice versa.

Each RF path contains a high pass filter to suppress the residual 50 Hz voltage in order to prevent damage of the RF input. Both the neutral line and phase line are equipped with a 275V varistor to ground. Furthermore, the RF path is protected by a 50V gas discharge tube.

Aside from that, there are no protective components. It is strongly advised to always employ external protection, such as attenuators or combined attenuators/limiters. Remove external protection only if you need to extend the dynamic range of the measurement and are confident that the EUT emissions do not exceed your spectrum analyzer's maximum input ratings. Be cautious that such emissions may go unnoticed if you do not monitor the frequency band below 150 kHz or 9 kHz.

Warning:

Unlike oscilloscopes, spectrum analyzers' RF inputs commonly offer no protection against high amplitude spurious or transients. Maximum input ratings typically vary from +20 to +30 dBm.

To protect the spectrum analyzer RF input from transients, unplug the coaxial cable when turning on/off the EUT. Use external attenuators or an attenuator/limiter/ high pass filter device such as the TBFL1 to examine the lower frequency range for spurious signals with high amplitude until you are certain, that the spurious levels do not exceed the spectrum analyzer 's maximum input ratings. As the limiter is a non-linear component, high amplitude spurious can create intermodulation and falsify the measurement result. Use external attenuators instead, if you suspect that the limiter is causing non-linear distortions.

1.4 Informative schematic

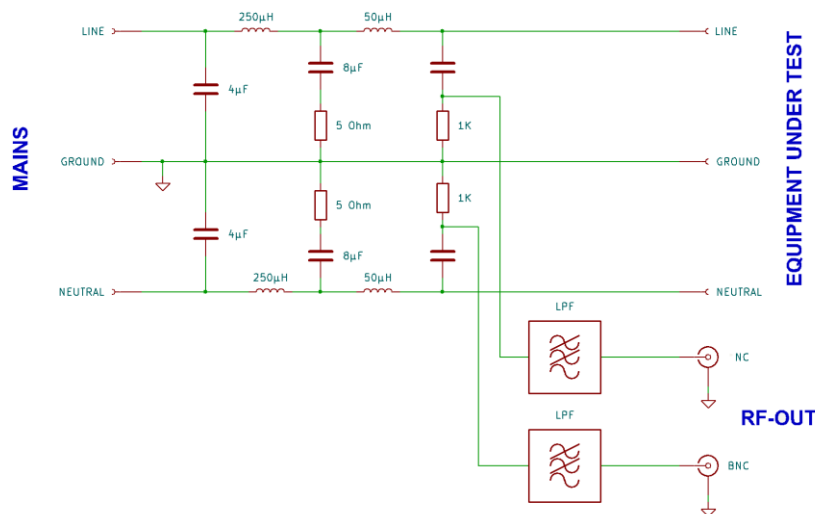

50 Ω // (50 μ H + 5 Ω) LISN, informative schematic

NOTE that the high capacitance values cause approximately 800mA reactive current at 50Hz/60Hz line voltages. Direct connection to the mains outlet would trip the ground fault protection switch. Refer to the next chapter on how to set up the LISN in a standard laboratory environment.

TBL5008-2B 50 μ H LISN

1.5 PE Switch

The protective earth switch connects the earth pin of the EUT socket either directly to LISN ground or in series with a parallel combination of a 50 μ H choke and a 50 Ohm resistor.

Engaging the 50 μ H choke // 50 Ohm resistor network decouples the protective earth of the EUT RF-wise from the protective earth of the LISN. This way, the effect of long extension cords on the EUT's EMC suppression circuitry can be tested.

1.6 Artificial hand

When performing conducted noise measurements with devices which are held in hand, the artificial hand network mimics the influence of the human hand. Examples for such devices are power tools, hair driers, kitchen tools and similar equipment.

Insulated housing sections that are touched by the hand when operating the equipment are covered with metal foil and connected to the artificial hand jack.

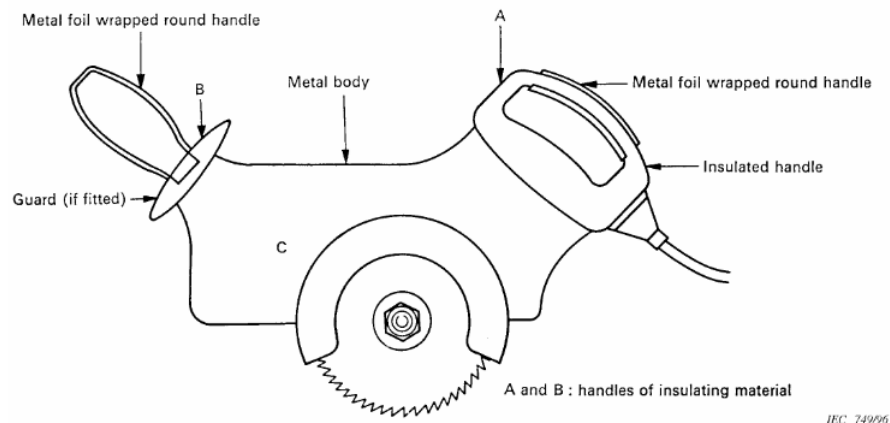

Example from CISPR 16, portable electric saw with artificial hand

1.7 Common mode / differential mode separator (LISN Mate) connectivity

Most LISN do not output common and differential mode emissions separately. The signal at the RF output is the sum of differential and common mode noise. Most EMC standards do not specify a distinct measurement, but studying the emissions with respect to its components might assist the engineer make judgments on the design of EMC suppression filters.

Separating the noise into common and differential mode signals can only be performed by combining the outputs of both LISN paths.

TBL5008-2B 50μH LISN

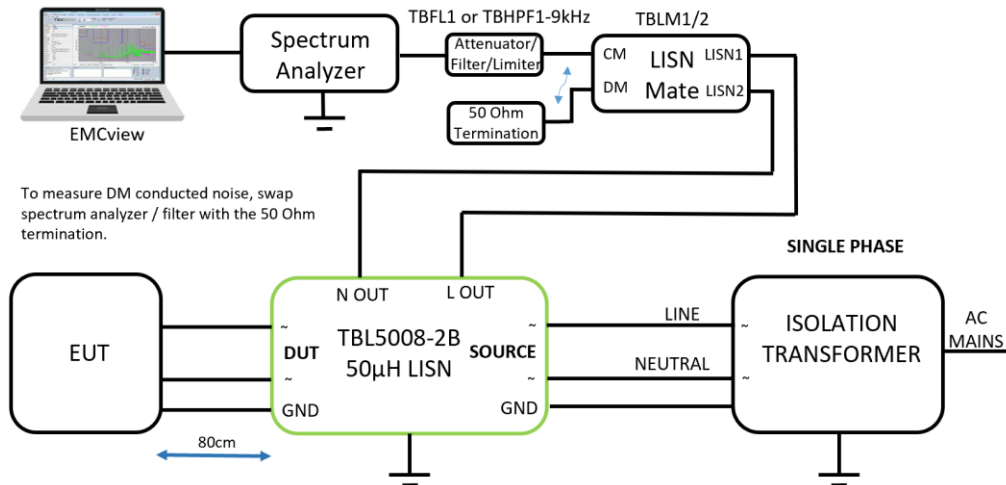

TBL5016-2 combined with a LISN Mate to separately measure common / differential mode noise

Follow the specifications of the applicable EMC standard for the setup's layout and ground plane connectivity

2 Laboratory set up

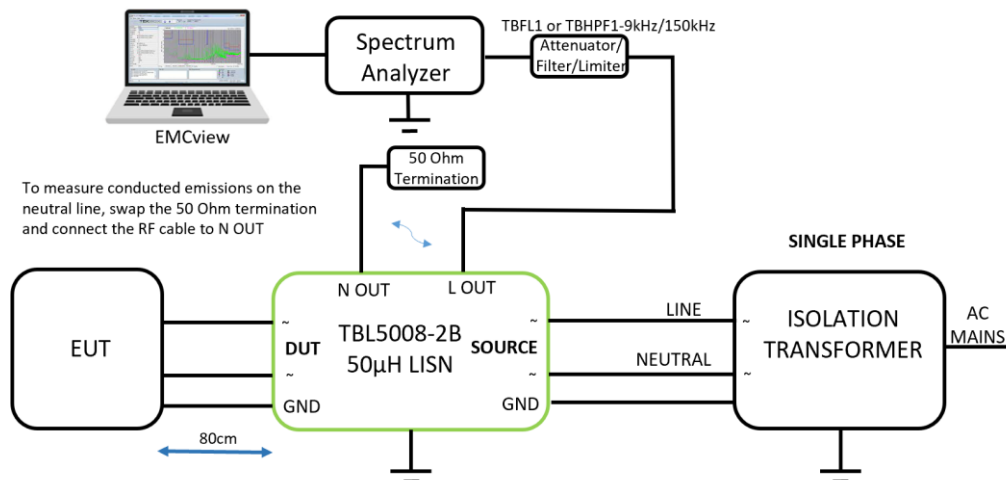

Basic wiring diagram for conducted emission measurements

A typical setup places the LISN on an 80 cm-high wooden table. The groundplane is positioned both on the wall and on the floor. The EUT is placed on the table, 40 cm in front of the groundplane on the wall. The LISN is placed on the groundplane on the floor.

For the detailed setup, follow the drawings and specifications in the applicable standard.

SAFETY: Ensure that all required earth connections are reliably bonded and that the isolation transformer can supply the required load current.

TBL5008-2B 50 μ H LISN

2.1 Ground plane

Any voltage measurement must be made against a common circuit node which can be referred to as the “zero volt” reference. In order to provide a low impedance zero volt reference for RF measurements, a metal sheet must be provided as ground plane. All ground straps between equipment and ground plane shall be as short as possible and fastened with screws. Exact details referring to the ground plane and the arrangement of the equipment and interconnecting cables are described in the applicable standards.

In a pre-compliance test setup, there may not always be enough space to install permanent ground planes.

Tekbox provides roll-up ground planes from conducted fabrics that can be setup temporarily and removed and stored easily.

2.2 Pre-compliance setup with roll-up ground plane

The TBGP-250/140-B roll-up ground plane consists of a conductive fabric bonded to a fleece. The ground plane is 250 cm long and 140 cm wide.



The ground plane has eyelets on both short sides for convenient storage and deployment. Metal spring clamps or fabric rivets can be used to connect Earth.

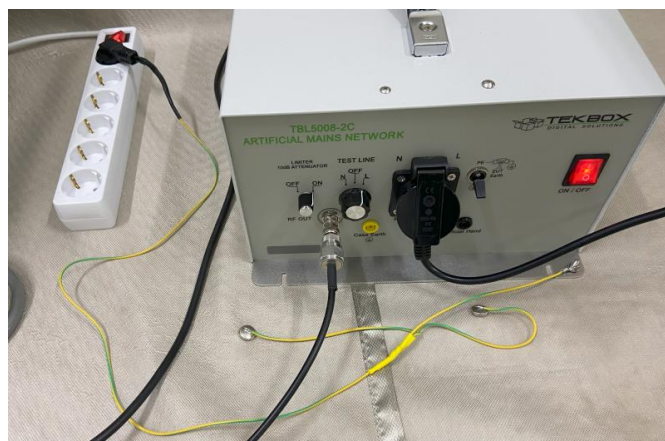
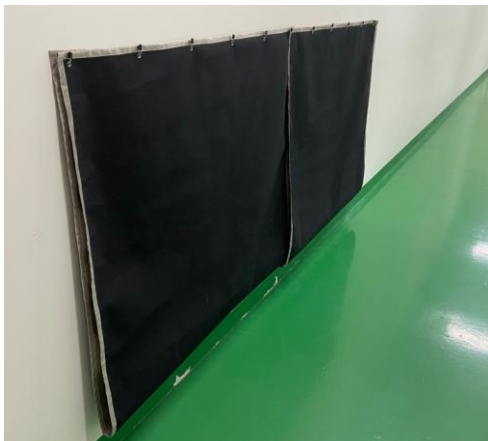

TBL5008-2B 50 μ H LISN

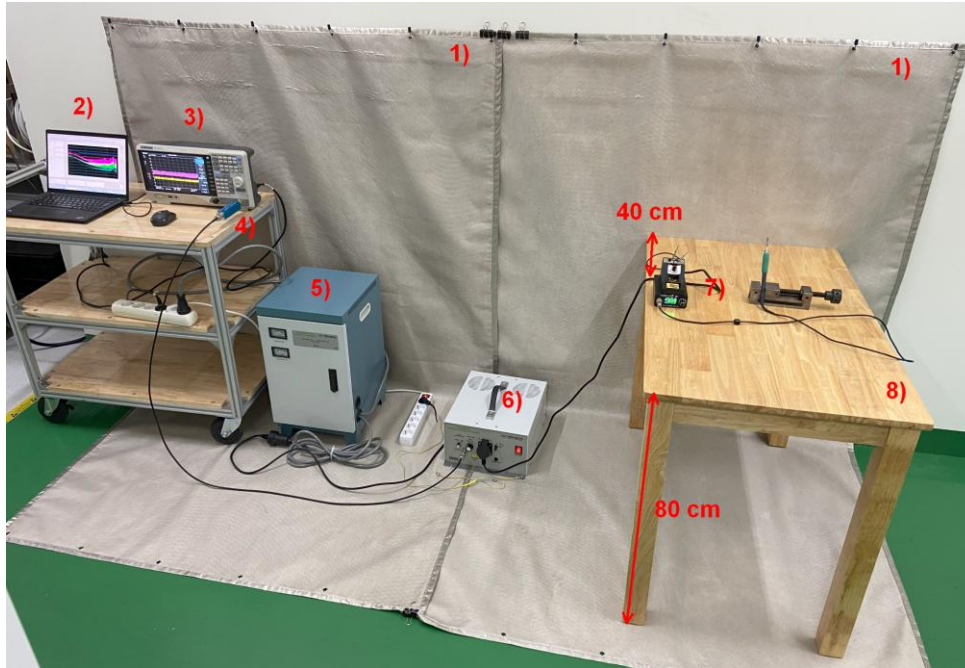

Example pre-compliance set up:

- 3) spectrum analyzer
- 6) LISN

- 1) roll-up ground planes
- 4) TBFL1 transient limiter
- 7) EUT

- 2) PC, EMCview software
- 5) isolation transformer
- 8) wooden table

3 Operation checklist

- Setup the isolation transformer, TBL5008-2B, EUT and spectrum analyzer according to chapter 1.5.
- Before powering the isolation transformer, measure the connectivity between each equipment chassis and ground plane.
- Ensure that the supply cable of the isolation transformer, the supply cable of the LISN, the supply cable of the spectrum analyzer and if applicable the supply cable of the EUT contain a ground conductor.
- Ensure that the Protective Earth switch is set to direct ground position unless you want to simulate an extension cable.
- Ensure that the analyzer input is protected with an external attenuator or attenuator /limiter and the RF cable is not yet connected to the LISN RF output. Ensure that the unused RF channel is terminated with 50 Ohm.
- Ensure that the power switch of the TBL5008-2B is in “OFF” position.
- Ensure that the EUT power switch is in “OFF” position.
- Power on the isolation transformer
- Power on the spectrum analyzer, set frequency, bandwidth, amplitude etc.
- Power on the TBL5008-2B and then power on the EUT
- Connect the RF cable and carry out the conducted noise measurements.

After finishing the measurement, proceed in reverse order. Take special care to disconnect the RF cable before powering off the EUT.

TBL5008-2B 50 μ H LISN

4 TBL5008-2B specifications

4.1 Conformity

The TBL5008-2B is compliant with CISPR 16-1-2.

In line with the CISPR 16-1-2 standard compliant design and setup specification, the TBL5008-2B V-LISN exhibits high ground leakage currents and non-standard isolation and consequently cannot meet the safety requirements of EN 61010-1.

Furthermore CISPR 16-1-2 specifies high capacitance values for the capacitors from Line and from Neutral to Ground (PE). These capacitance values are not commercially available in Y2 rating and are implemented using AC rated capacitors with suitable voltage rating.

In order to prevent the danger of lethal electric shock, the operator is responsible for ensuring protective measures in line with IEC 60364-4-41 and IEC 60364-5-54 and to follow all safety related information of this manual.

4.2 Safety

In order to ensure safe operations, the user must follow all safety relevant information of this manual. All housing parts are connected with the earth conductor of the power cable, EUT socket, yellow banana receptacle and with the ground strap of the housing. It is not allowed to carry out any modifications or manipulations of the TBL5008-2B. The TBL5008-2B shall be operated by qualified laboratory staff only.

4.3 Specifications

- Frequency range: 9 kHz to 30 MHz
- Impedance: 50 Ω || (50 μ H + 5 Ω)
- Artificial hand: 220 pF + 511 Ω
- Separate BNC outputs for line and neutral to provide connectivity for CM / DM separators (LISN Mate)
- Switchable PE: 50 Ω || 50 μ H; simulates effects of extension cable drums for power tools
- Line voltage: max. 250V / 50 – 60 Hz or DC
- Max. current: 8 A @ 23°C; Fuses: 8 A, slow
- EUT socket: country specific
- Measurement connector: 50 Ω BNC
- Power connector: IEC 60320 C13
- Operating Temperature Range: +5°C ... + 40°C; 5% to 80% RH
- Chassis grounding: protruding, stainless steel bottom panel, with 4mm mounting slots and holes
- Weight and dimensions: 8 kg; W x H x L – 35 cm x 18 cm x 41 cm

4.4 Supply voltage

The TBL5008-2B does not require any particular voltage settings. It can be operated with any supply voltage which does not exceed 250V, 50Hz/60Hz. It can also be used for DC powered EUTs

TBL5008-2B 50 μ H LISN

4.5 Front Panel

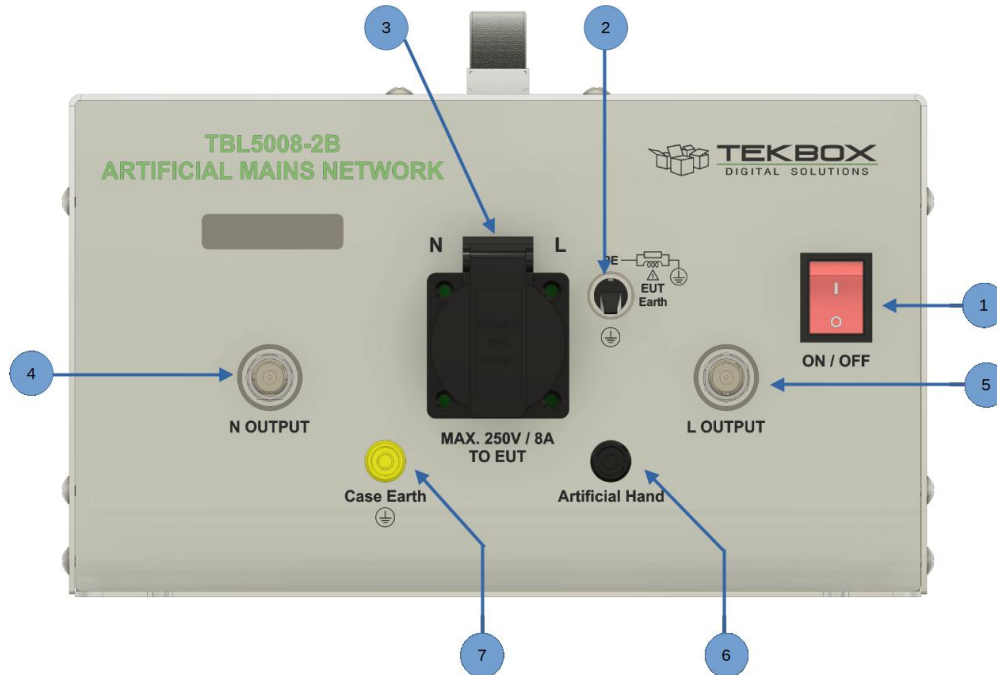

Front panel layout

- 1) Mains switch
- 2) Protective Earth switch to connect EUT earth either directly to case earth, or via 50 μ H || 50 Ohm; simulates extension cable drums
- 3) EUT socket, country specific
- 4) 50 Ω RF output, BNC jack, N (neutral)
- 5) 50 Ω RF output, BNC jack, L (phase)
- 6) Artificial hand connector, safety banana jack
- 7) Auxiliary case earth connector, safety banana jack

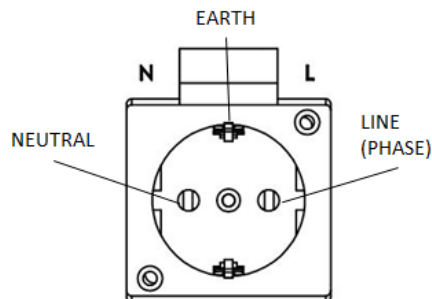

EUT connector, pin assignment with reference to the rear power connector *)

*) For Schuko sockets: depends on the orientation of the cable connected to the mains power outlet

TBL5008-2B 50µH LISN

4.6 Rear Panel

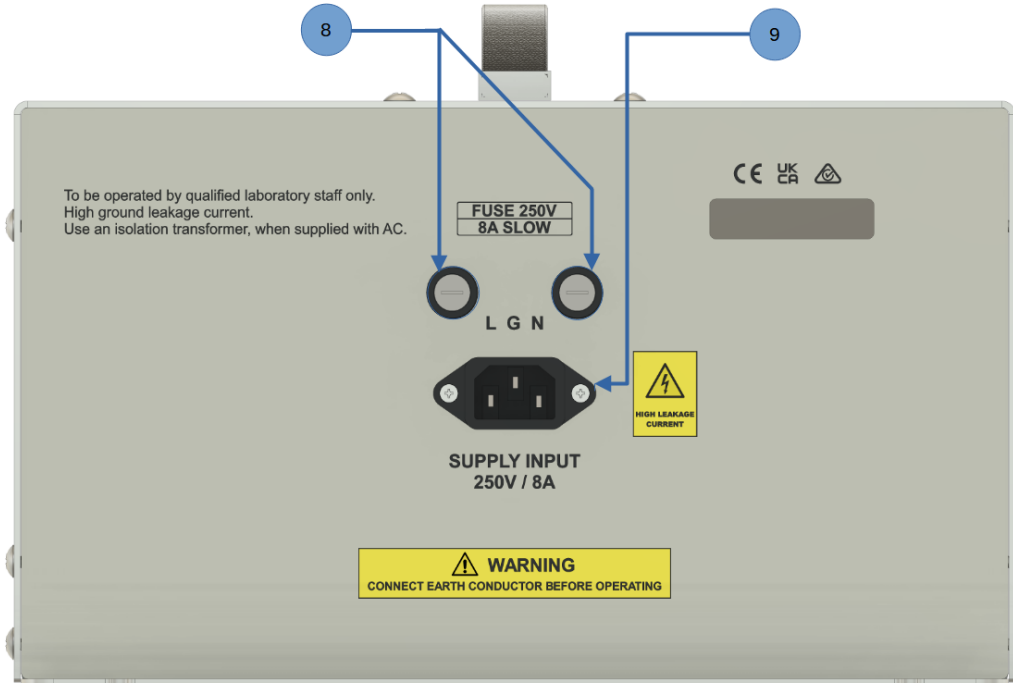

Rear panel layout

- 8) Fuses, 8 A, slow
- 9) Power socket: IEC 60320 C13

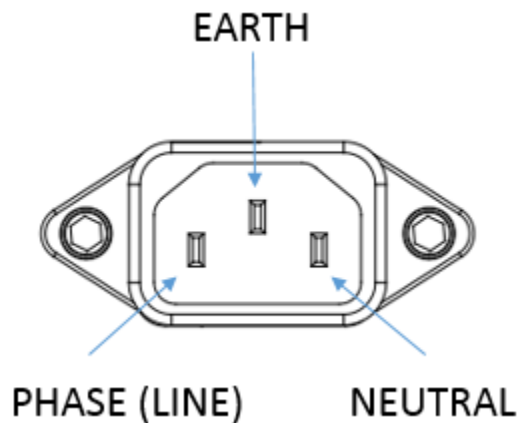

Mains connector, pin assignment *)

*) For Schuko connectors: Depends on the orientation of the plug with respect to the mains power outlet

TBL5008-2B 50 μ H LISN

4.7 Impedance

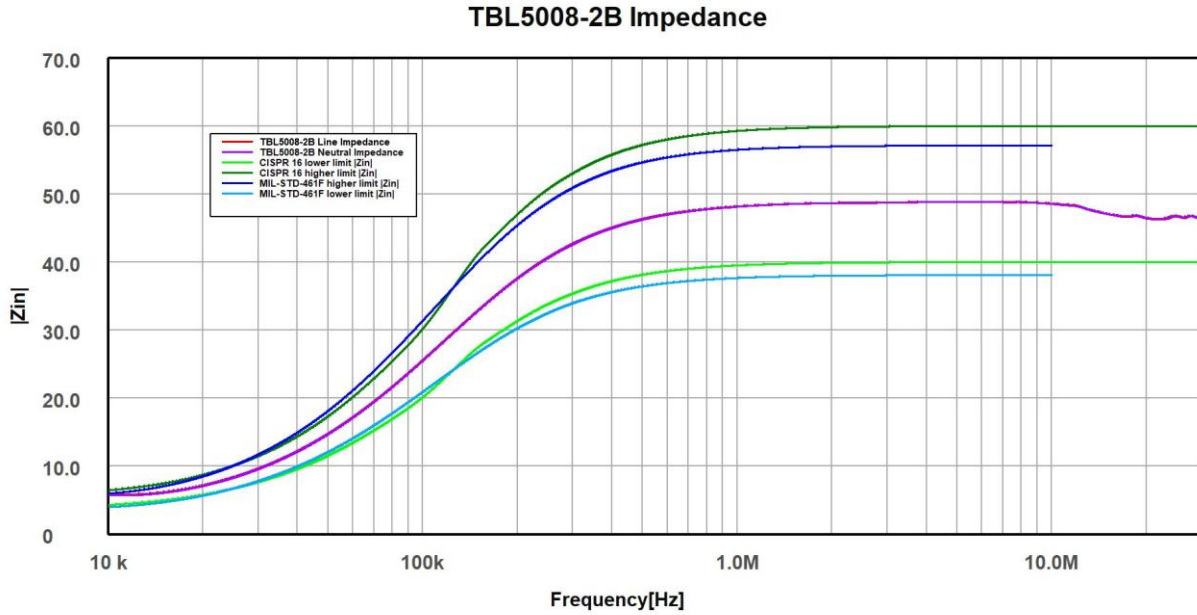

Impedance vs. frequency at EUT terminals

4.8 Phase

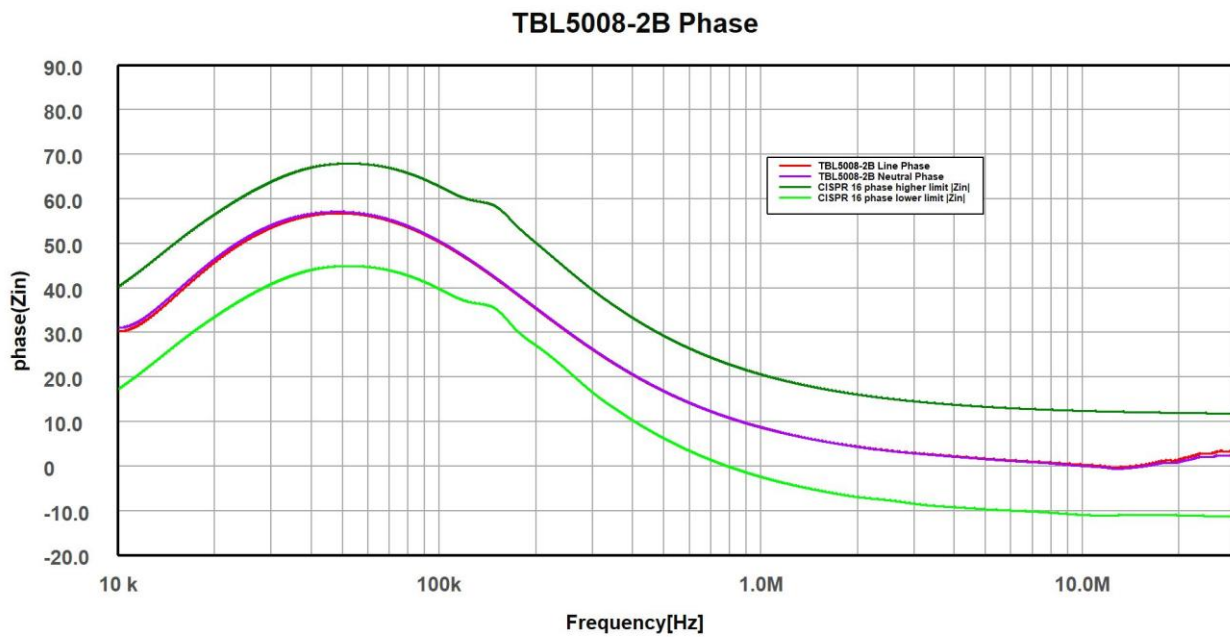

Phase angle vs. frequency at EUT terminals

TBL5008-2B 50 μ H LISN

4.9 Calibration data according to CISPR 16 -1-2 Annex A8

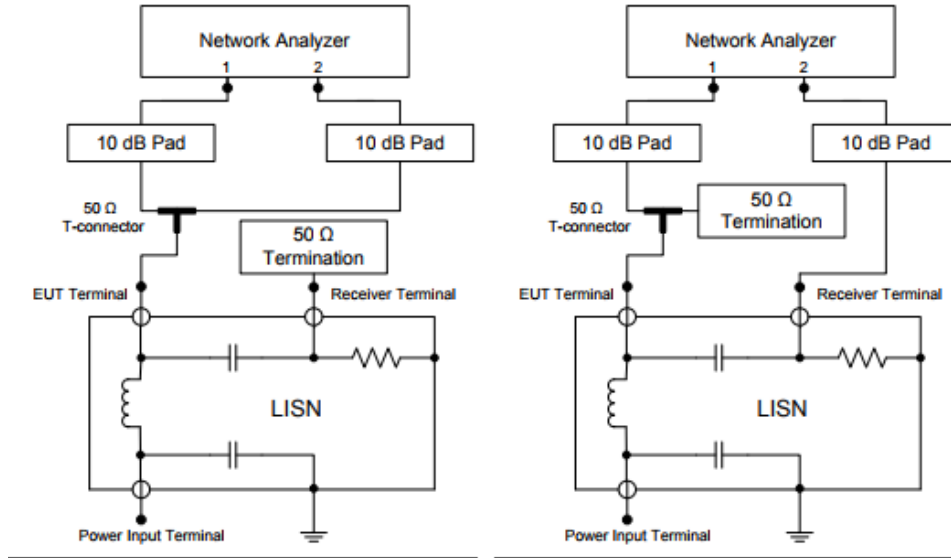

Reference measurement setup using network analyzer.

Transmission measurement setup using network analyzer.

Calibration set up according to CISPR 16-1-2 Annex A.8.

TBL5008-2B Voltage Division Factor

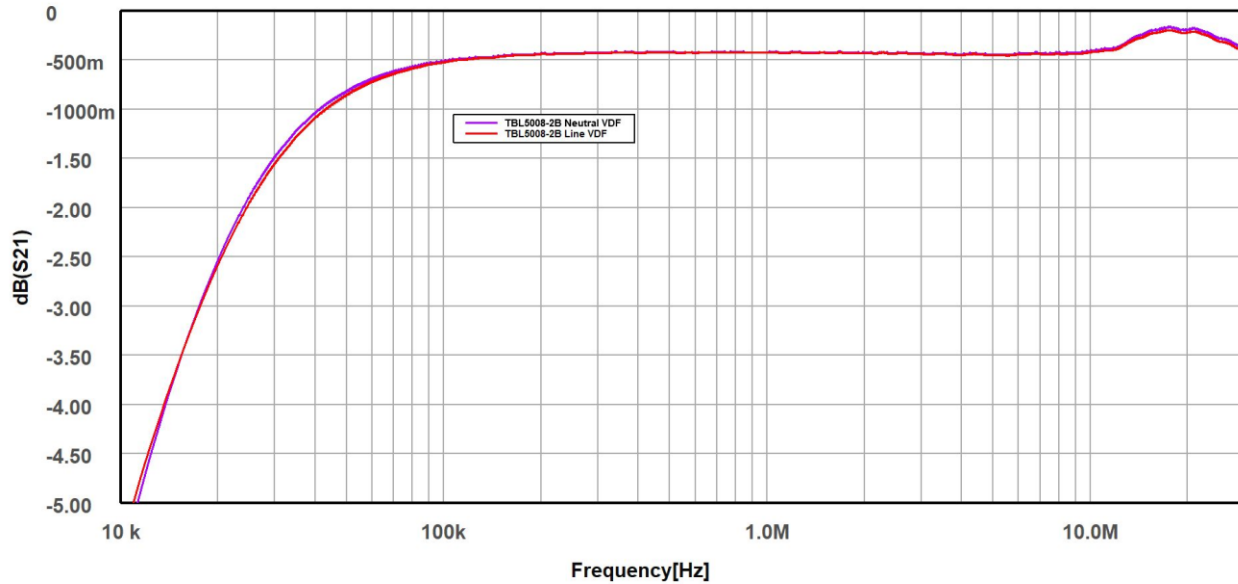

Voltage Division Ratio versus frequency

TBL5008-2B 50µH LISN

Frequency[MHz]	VDR Neutral [dB]	VDR Line [dB]
0,009	-6,07	-6,38
0,015	-3,61	-3,63
0,02	-2,59	-2,54
0,03	-1,56	-1,49
0,05	-0,86	-0,82
0,075	-0,61	-0,59
0,1	-0,53	-0,51
0,15	-0,47	-0,46
0,2	-0,44	-0,44
0,3	-0,43	-0,43
0,5	-0,42	-0,42
0,75	-0,43	-0,42
1	-0,43	-0,42
1,25	-0,43	-0,42
2,5	-0,44	-0,43
5	-0,45	-0,45
7,5	-0,45	-0,44
10	-0,42	-0,41
20	-0,22	-0,19
30	-0,39	-0,36

Table 1, TBL5008-2B LISN voltage division ratio, calibration data

4.10 Isolation

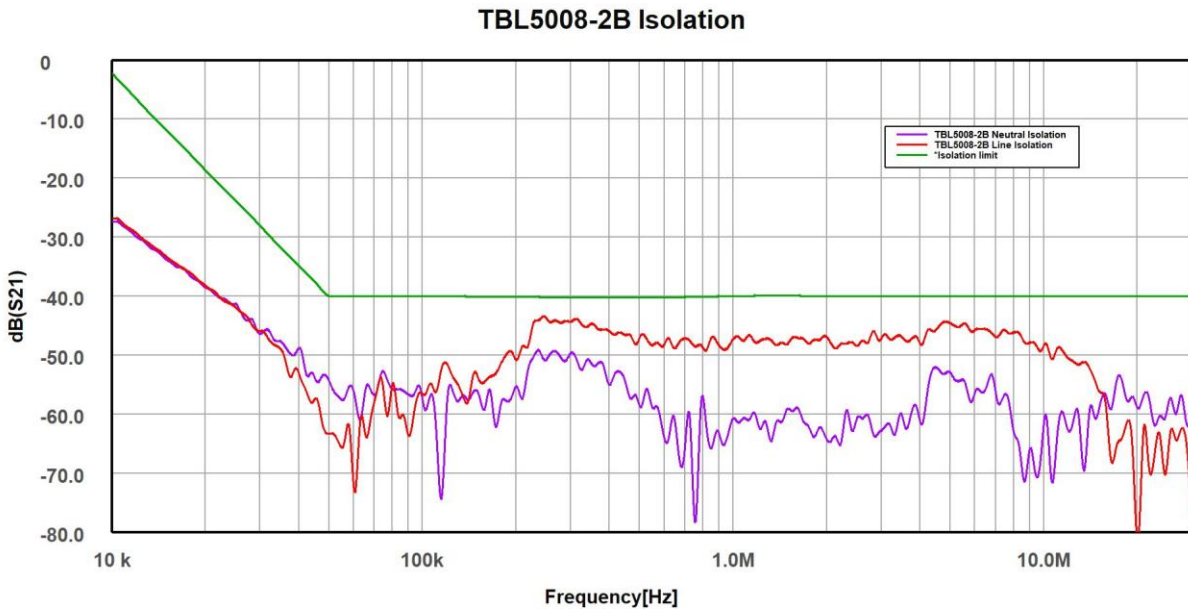

TBL5008-2B 50µH LISN

4.11 Thermal characteristics

Avoid touching the housing, when operating the LISN at maximum current over extended time. Turn off the EUT after measurements to avoid unnecessary dissipation.

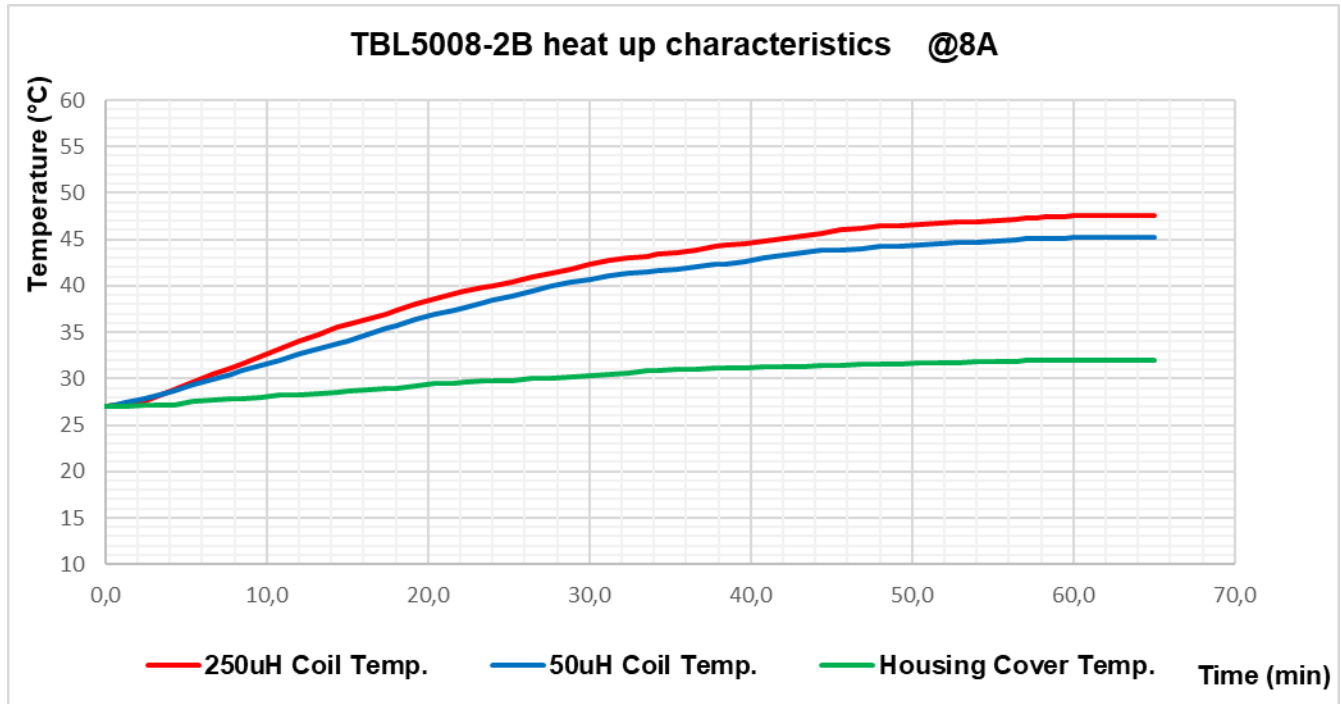

Coil and housing temperature at 8 A EUT current @ 27 °C ambient temperature

5 Ordering Information

Part Number	Description
TBL5008-2B-EU	50µH LISN with Schuko socket (CE7/3, 8 A), 8 A cold appliance cable, 75 cm coaxial cable BNC-male / N-male/RG223, BNC - Termination
TBL5008-2B-US	50µH LISN with US socket (NEMA 5-15, grounded, type B, 15A), 15A cold appliance cable, 75 cm coaxial cable BNC-male / N-male/RG223, BNC - Termination
TBL5008-2B-AU	50µH LISN with Australian socket (AS/NZS 3112:201, 15A), 15A cold appliance cable, 75 cm coaxial cable BNC-male / N-male/RG223, BNC - Termination
TBL5008-2B-UK	50µH LISN with English socket (BS1363, 13A), 8 A cold appliance cable, 75 cm coaxial cable BNC-male / N-male/RG223, BNC - Termination
TBL5008-2B-xx	Any other socket requirements upon customer request will have 3-4 weeks lead time

Table 2– LISN Ordering Information

TBL5008-2B 50 μ H LISN

LISN Accessories

Part Number	Description
TBSP-8-Schuko	Rewirable 8 A Schuko (CEE 7/4) plug for extension cables
TBLCAC-08-EU	Additional cold appliance cable, 8 A, 1.8m, C13 to country specific (-EU/US/UK/AU)
TBLCAL - EU	Calibration adapters SMA-F-CE7/3 Neutral + SMA-F-CE7/3 Line
TBLCAL - US	Calibration adapters SMA-F-NEMA 5-15 Neutral + SMA-F- NEMA 5-15 Line
TBLCAL - AU	Calibration adapters SMA-F-AS/NZS 3112:201 Neutral + SMA-F-AS/NZS 3112:201 Line
TBLCAL - UK	Calibration adapters SMA-F- BS1363 Neutral + SMA-F- BS1363 Line

Protection accessories

Part Number	Description
TBFL1	External 10 dB attenuator / Limiter / High Pass Filter
TBAS1	3, 6, 10, 20dB attenuator set, N-Male / N-Female, 2 W, DC – 3 GHz
TBAS4	3, 6, 10, 20dB attenuator set, N-Male / N-Female, 2 W, DC – 6 GHz
TBHPF1-9kHz-B	External 9 kHz High Pass Filter
TBHPF1-150kHz-B	External 150 kHz High Pass Filter
TBHPF2-150kHz	External 150 kHz High Pass Filter
TBHPF3-150kHz	External 150 kHz High Pass Filter

Other Accessories

Part Number	Description
TBGP-250/140	Roll Up Ground Plane, 250 cm x 140 cm
TBLM2	LISN-Mate, Common Mode / Differential Mode separator
TBMR-110M	Measurement Receiver, DC – 110 MHz

6 History

Version	Date	Author	Changes
V1.0	3.2.2025	Mayerhofer	Creation of the document
V1.1	10.3.2025	Mayerhofer	Chapter 5 updated

Table 3– History

www.tekbox.com TekBox Digital Solutions Vietnam Pte. Ltd.

Factory 4, F4, Lot I-3B-1, Saigon Hi-Tech Park, Tan Phu Ward, District 9, Ho Chi Minh City, Vietnam